

Kurva Beban Arus Fase R Genset I

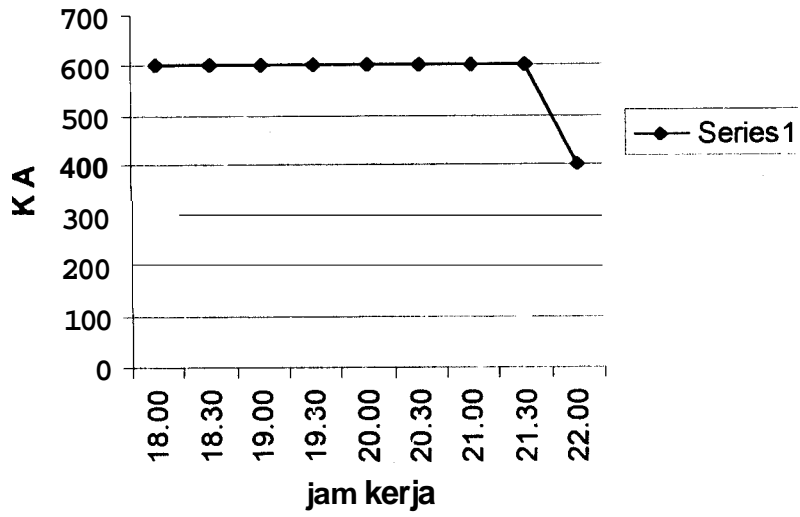

Kurva Beban Arus Fase R Genset II

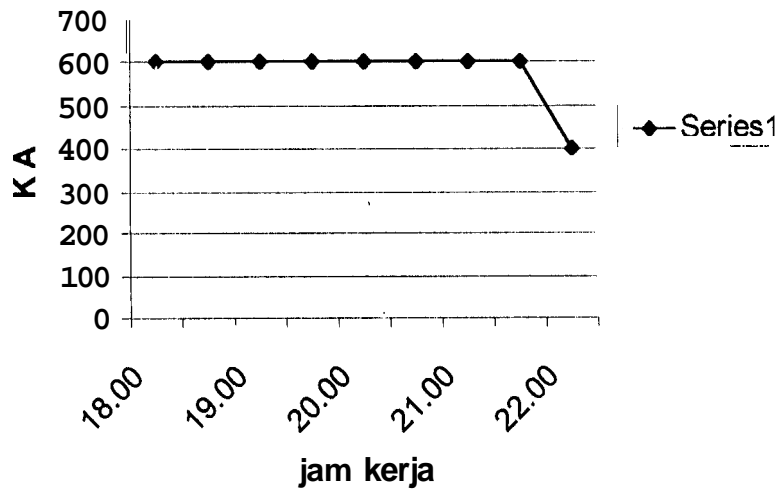

Kurva Beban Arus Fase S Genset I

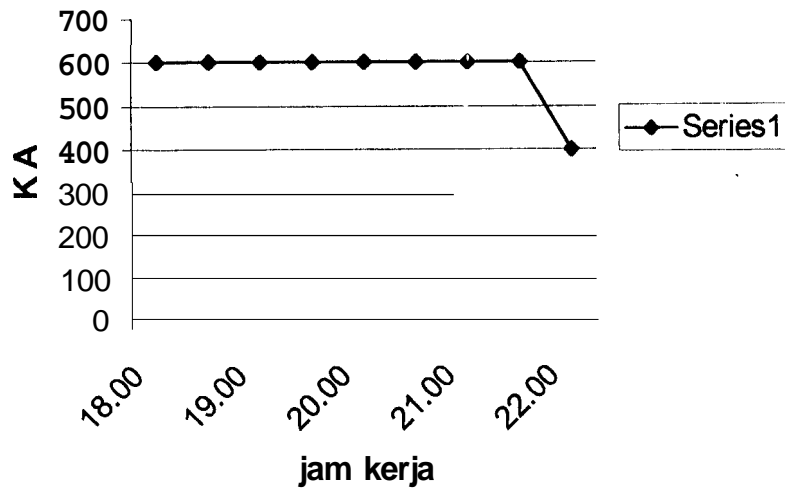

Kurva Beban Arus Fase S Genset II

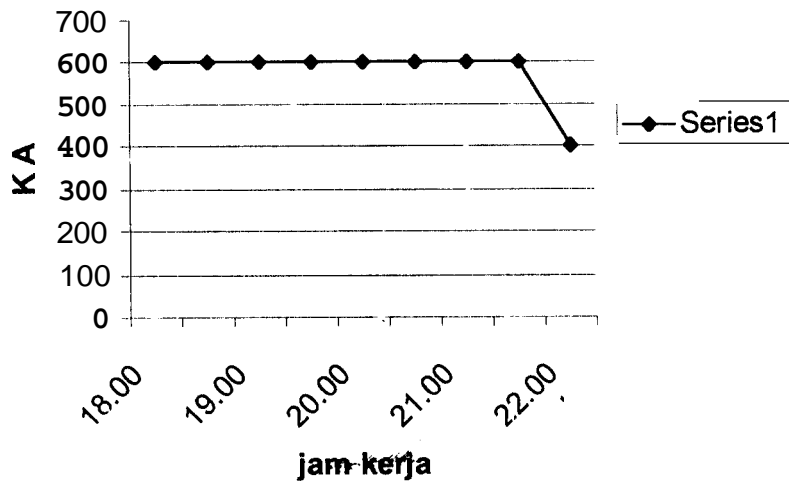

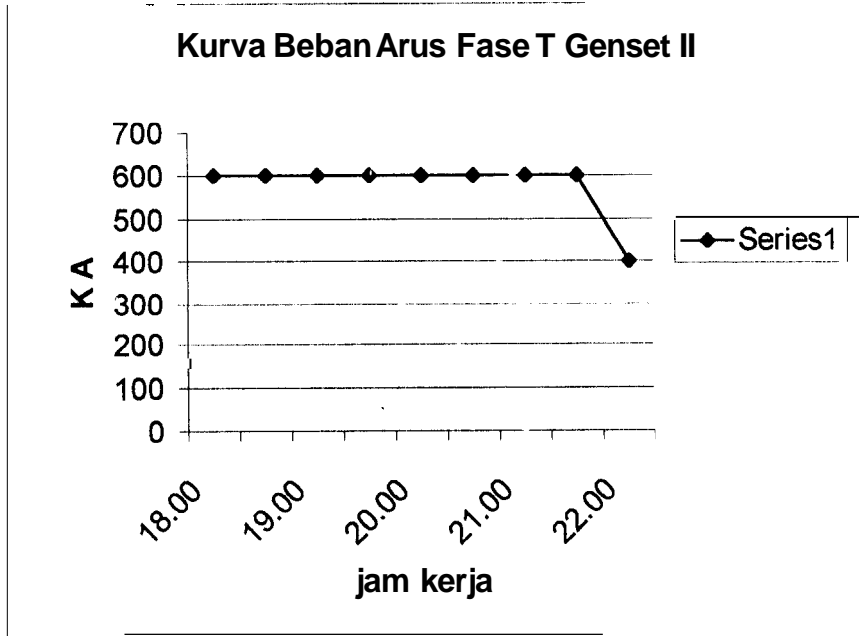
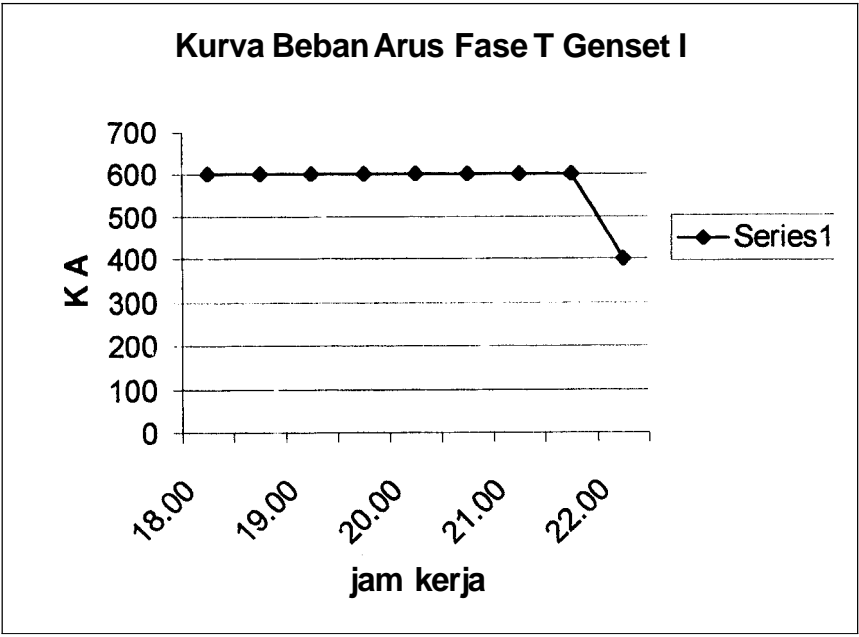

Kurva Beban KW Genset I

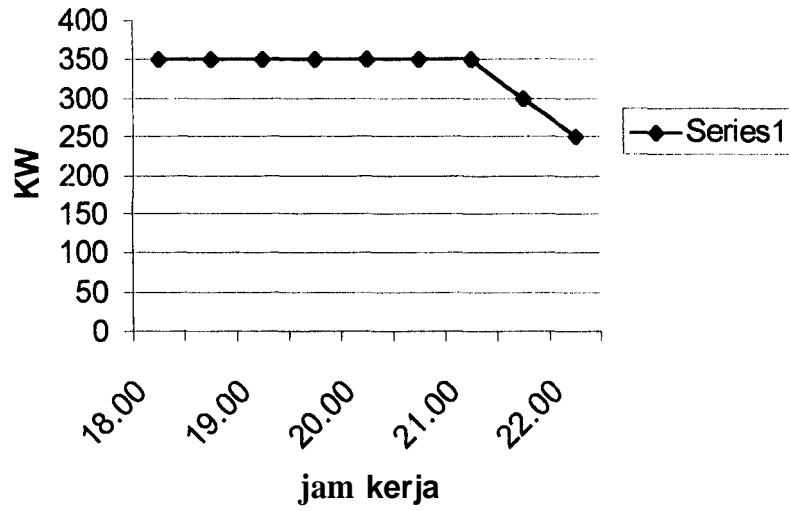

Kurva Beban KW Genset II

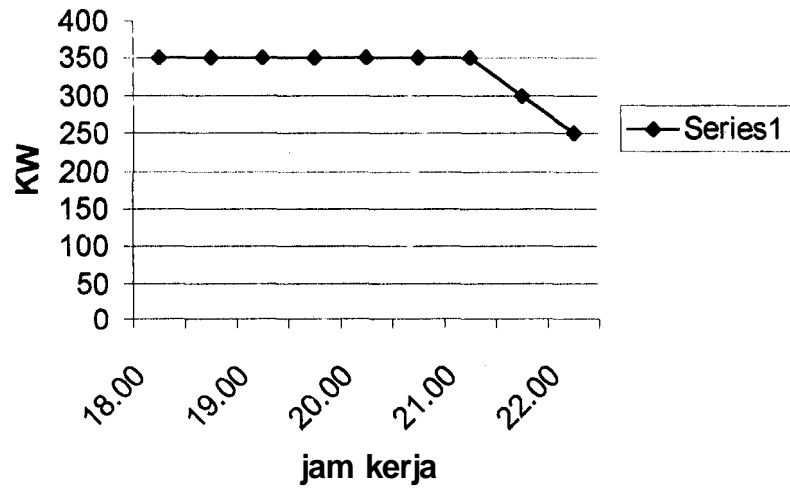

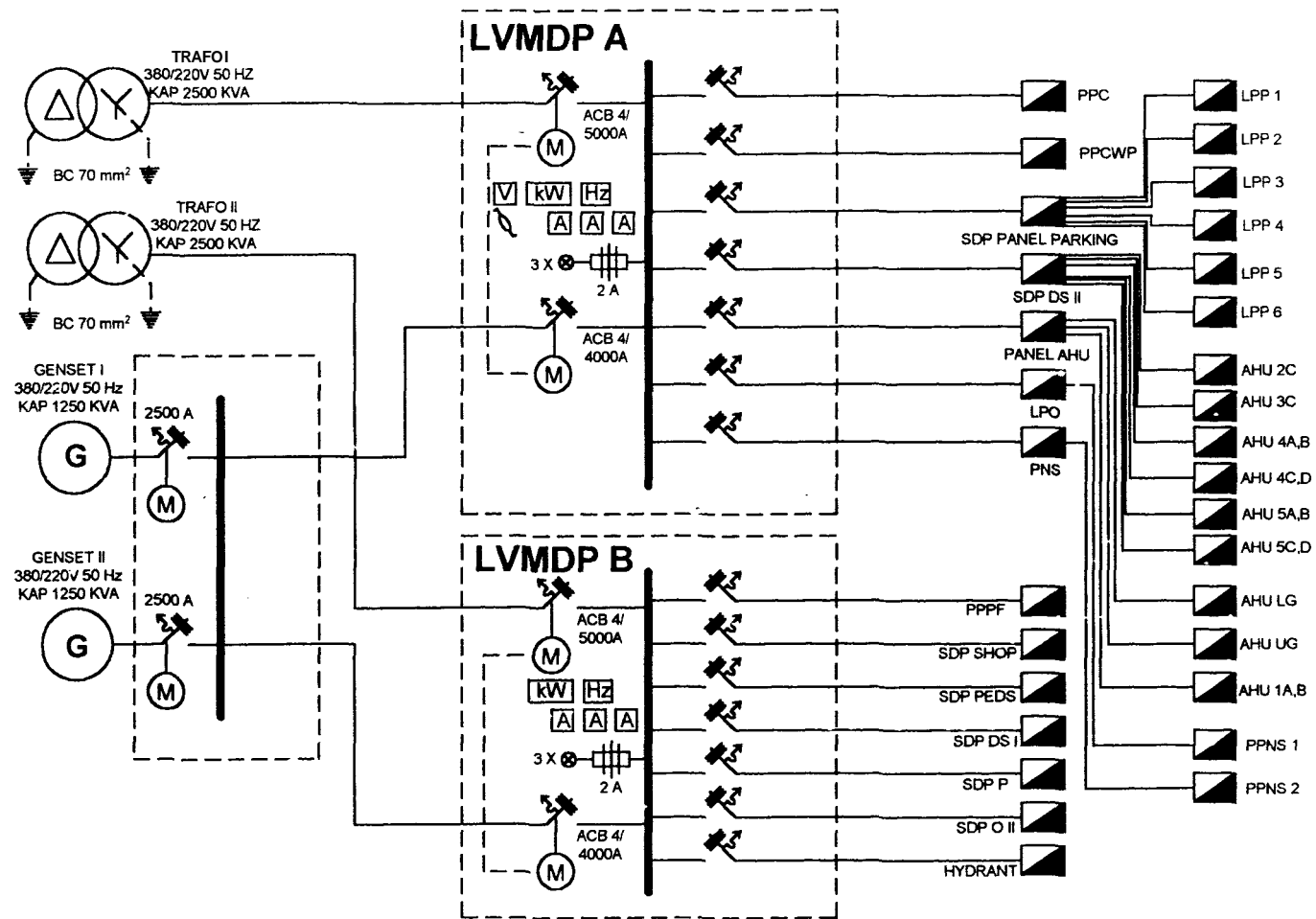

SINGLE LINE DIAGRAM TP II

**FAKULTAS TEKNOLOGI INDUSTRI
JURUSAN TEKNIK ELEKTRO
UNIVERSITAS KRISTEN PETRA
SURABAYA**

USULAN TUGAS AKHIR

Nama Mahasiswa : Harris
Nrp Mahasiswa : 23494069
Bidang Studi : **Sistem Tenaga**
Judul : **Studi Tentang Pembagian Beban Pada Generator
Set (2 X 1,25 MVA) di Tunjungan Plaza II**
Pembimbing I : **Ir. Emmy Hosea, M.Eng,Sc**
Dilaksanakan : **Semester gasal tahun 2001/2002**

Surabaya, 21 Juli 2001

Yang mengusulkan



Harris

Mengetahui :

Koordinator Tugas Akhir

Drs. Heri Saptono W, M.Si

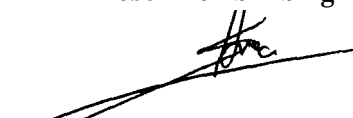
Dosen Pembimbing I

Ir. Emmy Hosea, M.Eng,Sc

1. JUDUL TUGAS AKHIR

Judul tugas akhir yang diusulkan adalah studi tentang pembagian beban pada generator set (2 X 1250 KVA) di Tunjungan Plaza II.

2. LATAR BELAKANG PEMILIHAN JUDUL

Sistem pembangkitan listrik sangat dibutuhkan dalam rangka memenuhi kebutuhan daya listrik baik untuk industri maupun rumah tangga. Tentunya suplai daya listrik ini untuk memenuhi beban listrik yang ditimbulkan akibat pemakaian listrik yang terus meningkat. Suplai listrik ini diperoleh dari sumber energi listrik baik itu dari PLN maupun dari generator set. Pada generator set, agar kualitas daya listrik dapat meningkat maka perlu kerja paralel generator sehingga suplai listrik ke beban menjadi merata, untuk itu diperlukan suatu sistem pembagian beban (Load sharing) yang dapat mengatur besar beban yang ditanggung oleh masing-masing generator, sehingga efisiensi generator set yang lebih baik dapat diperoleh.

3. PERUMUSAN MASALAH

1. Mempelajari ruang pembangkit
 - konstruksi ruang

- komponen-komponen penting PLTD
2. Mempelajari dan menganalisa cara kerja generator set.
 - 3, **Mempelajari** dan menganalisa kerja paralel generator set :
 - persyaratan
 - keuntungan
 - cara penyoperasian
 4. Mempelajari single line diagram
 5. Mempelajari dan **memahami** beban-beban yang *menggunakan listrik* dari generator set.
 6. Mempelajari dan menganalisa efisiensi load sharing (pembagian beban) **pada** generator set.

4. TUJUAN TUGAS AKHIR

Mempelajari dan memahami cara kerja generator set dan kerja paralel generator set, juga **untuk studi** banding antara teori yang **didapat pada** perkuliahan dengan kenyataan **di** lapangan sehingga dapat **memahami** dan **mengetahui** secara praktis kerja paralel generator set. Sehingga dapat diketahui manfaat load sharing terhadap efisiensi generator set.

5. TINJAUAN PUSTAKA

Bila kita mempelajari tentang sistem pembagian beban (load sharing) pada generator set, maka hal yang penting untuk diperhatikan antara lain :

- sumber listrik yang digunakan
 - PLN
 - Generator set (genset)
- beban yang harus disuplai
 - a. sesuai dengan kebutuhan :
 - i. AC
 - ii. Penerangan
 - iii. Lift
 - iv. Escalator
 - b. besar beban harian

Di samping itu, blok diagram di bawah ini dapat menjelaskan tentang suplai listrik :

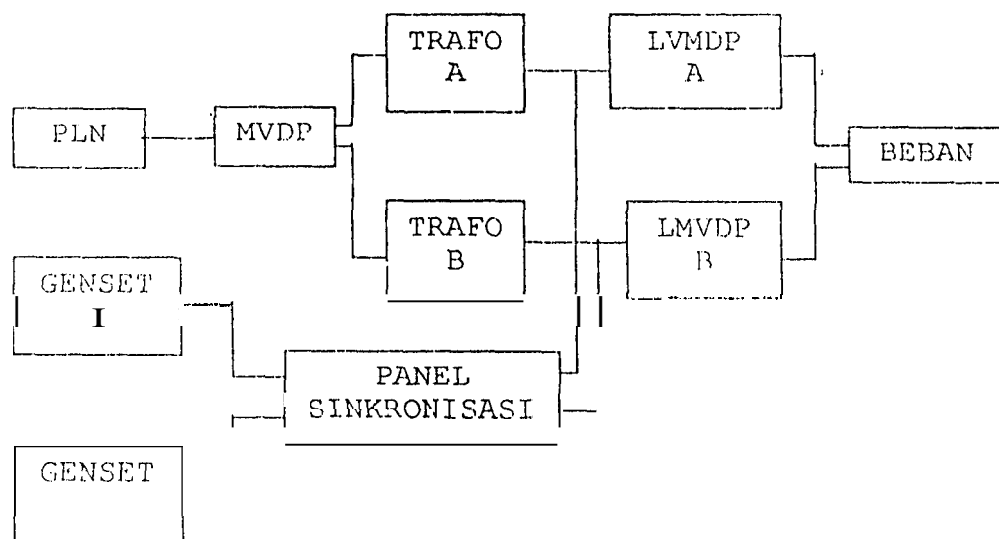

Dengan **melihat blok diagram di atas** , maka **terlihat bahwa** beban **terpasang** mendapat **suplai** utama dari **genset (2 X 1,25 MVA)**. Untuk beban yang **besar** maka **kerja** paralel generator set **diperlukan** agar **kapasitas daya yang diperlukan dapat** terpenuhi **dalam hal ini, diperlukan juga** :

- **tegangan incoming generator** sama dengan tegangan busbar
- **Frekuensi generator** harus sama dengan frekuensi busbar.
- **Urutan fasa incoming generator** harus sama dengan urutan fasa busbar.

Pembagian beban (load sharing) diatur oleh MDP (**main distribution panel**), alat **ini berfungsi untuk** :

- **membagi daya dari generator secara seridiri atau paralel ke generator lain** kemudian dialirkan ke bebau.

Dengan **demikian** pembagian beban erat **kaitannya** dengan beban **yang** disuplai oleh **generator set** yang **bekerja paralel** Dan **pengaturan pembagian beban** mempengaruhi **effisiensi kerja generator set**, sehingga **suplai daya listrik** oleh **masing-masing generator set yang bekerja paralel** semakin **maksimum**.

6. METOLOGI PENELITIAN

- **Studi Literatur**

Dalam pembuatan Tugas Akhir teori-teori yang digunakan untuk analisa antara lain, dengan studi **pustaka** meliputi :

- * **Mempelajari** suplai energi listrik terhadap beban
- * **Prinsip kerja generator' set**
- * **Mempelajari kerja paralel generator set**
- * **Mempelajari efisiensi load share pada genset**

- **Pengumpulan Data**

- * **Data lengkap** generator *set*
- * **Data-data** kurva beban **harian**
- * **Data single** line diagram
- * **Data sinkroisasi** genset

- **Analisa Data**

Setelah memperoleh data-data di atas, maka dapat dianalisa sejauh mana pengaruh pembagian beban (load sharing) pada efisiensi generator set.

* **Kesimpulan**

dengan load sharing sangat efisien **pada genset, mska** kebutuhan *akan* kualitas daya yang maksimal dapat terpenuhi.

7. RELEVANSI

Dengan **mengadakan studi tentang pembagian beban pada generator sei** di TP II ,dapar diperoleh informasi yang tepat tentang manfaatnya bagi peningkatan **kapasitas daya** yang **mana dapat** memenuhi **kebutuhan listrik yang** terus meningkat dewasa ini.

8. JADWAL KEGIATAN

Bulan Ke	1	2	3	4	5
1.Studi literature	*	*			
2.Pengumpulan data		*	*		
3. Analisa data			*	*	
4.Kesimpulan dan Pembuatan Laporan				*	*

9. DAFTAR PUSTAKA

- Clive T. Jones, Diesel Plant **Operation** Handbook, Mc-Graw Hill Inc, 1991.
- LL J Mahun ,Diesel Generator Handbook ,Butterworth Heineman ,1992.

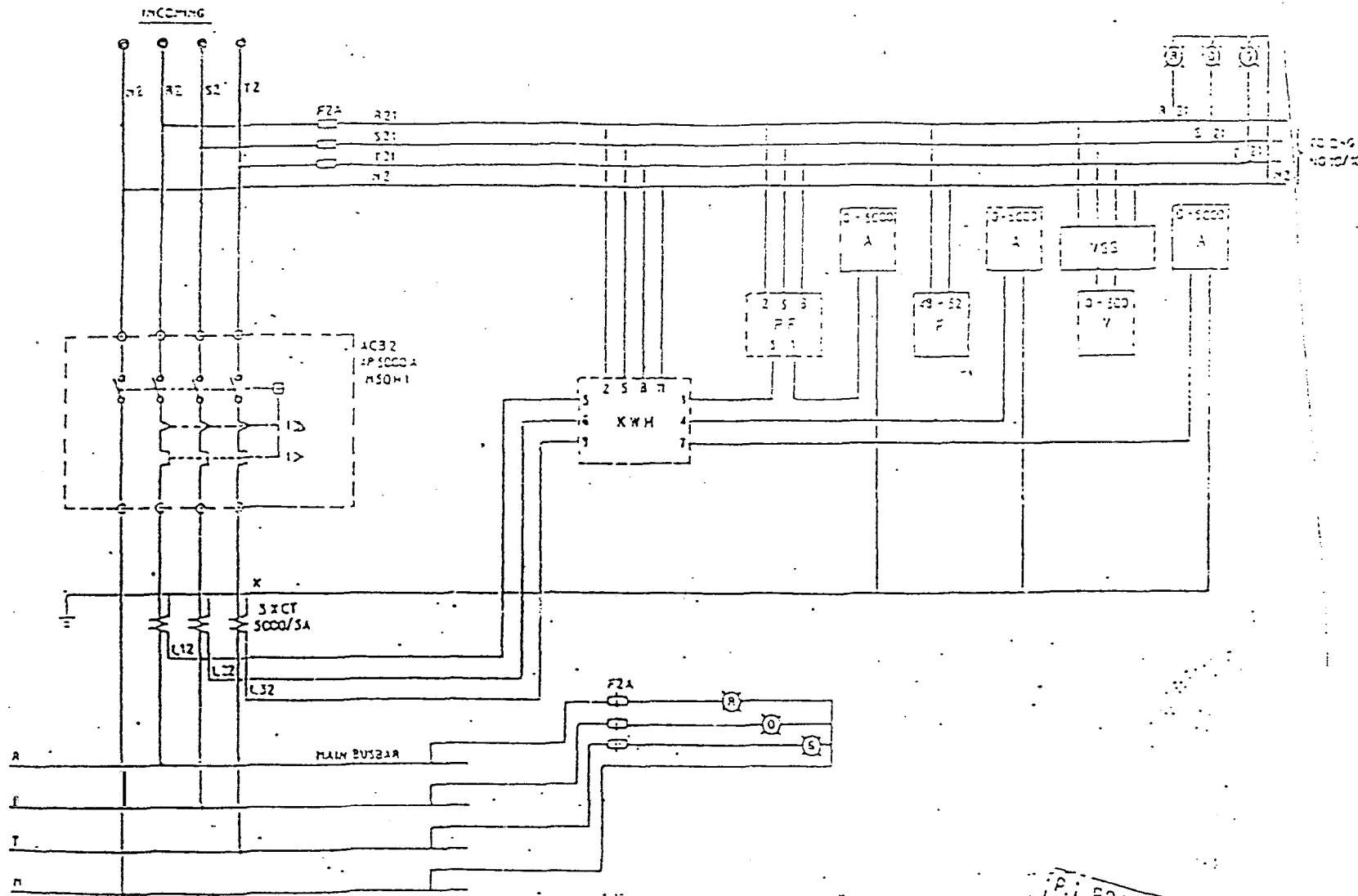

P. PRADIPTAYA
 PROJEK BBO TOWER
 TUNJUNGAN PLAZA 2
 SURABAYA



PT. PANINDO HARPER SENTOSA JAKARTA	PROJEK BBO TOWER TUNJUNGAN SURABAYA	No. 1 10/10/2010	1 2 3	7 10
	PT. PRADIPTAYA	LYNDOP - B	7	10

STANSET

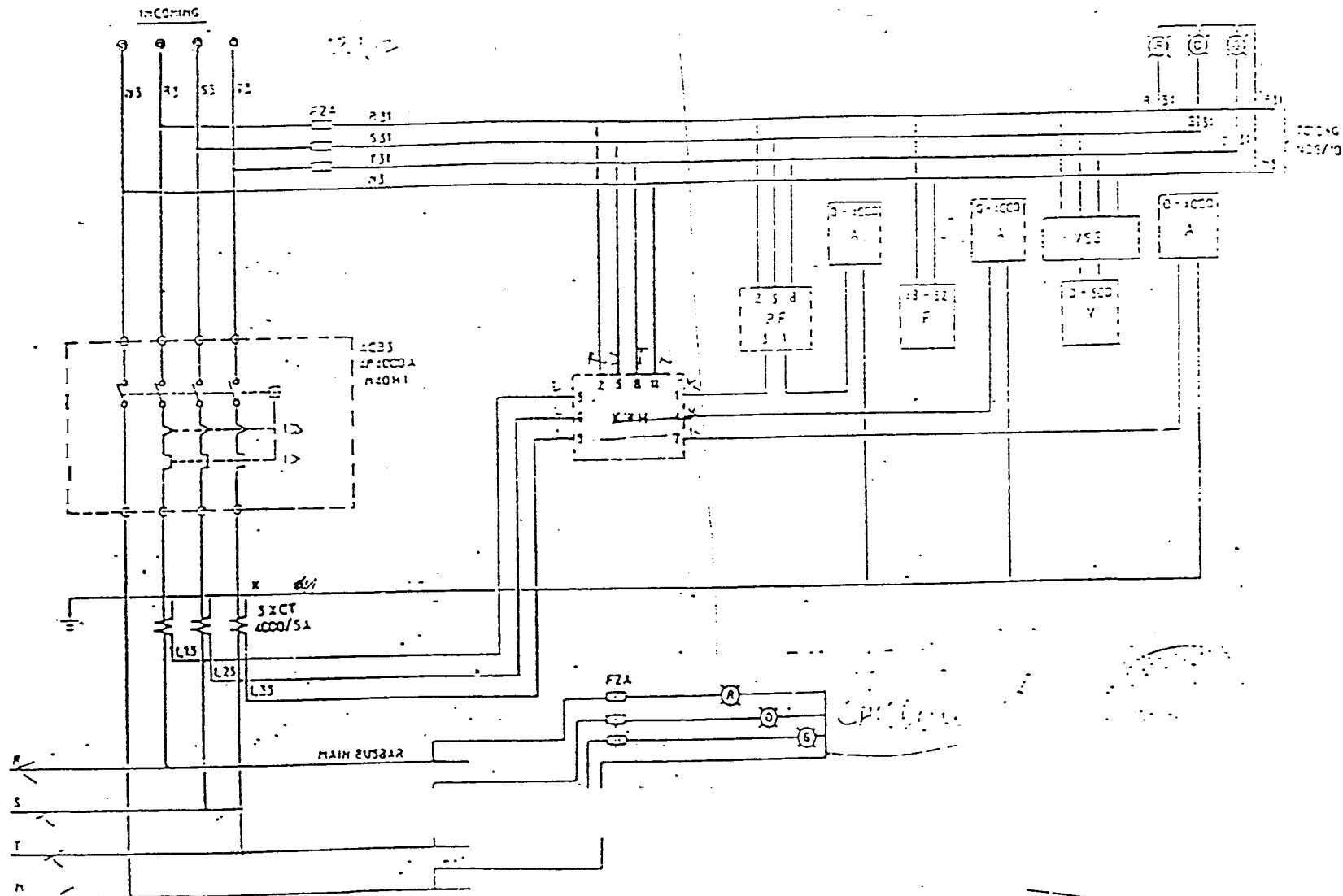

P.T. PRADIPTAYA
 PROYEK B30 TOWER
 TUNJUNGAN PLAZA I
 SURABAYA



	PT. PRADIPTAYA SURABAYA	PROYEK B30-TOWER	LOKASI: SURABAYA	NO. 1	2	3	REVISI NO.
	PRADIPTAYA	TUNJUNGAN-SURABAYA	NO. 1	1	2	3	6
	PRADIPTAYA	PRADIPTAYA	NO. 1	1	2	3	6

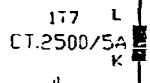
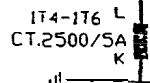
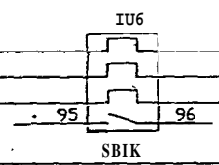
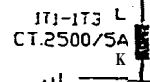
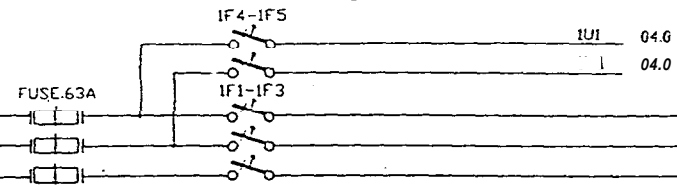
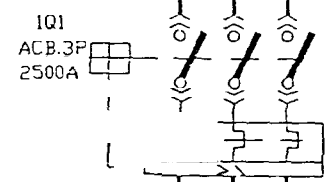
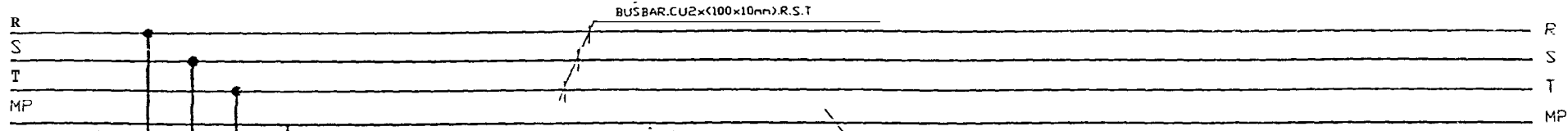

IN GENO.1-1250KVA
220/380V/50Hz-50Hz

IU1	02.1	
IU1	02.1	Grp
IU1	02.1	
IMP1	02.1	/ 04.0
IL1	032	
IL2	032	Grp
IL3	032	
IK1	032	
IL4	02.5	
IL5	02.5	
IL6	02.5	Grp (10)
IK2	02.5	
IL7	02.13	
IK3	02.13	

0	1	2	3	4	5	6	7	8	9	10	11	12	13	14	15	16	17	18	19
---	---	---	---	---	---	---	---	---	---	----	----	----	----	----	----	----	----	----	----

PT. PIONEER

JALAN Ir DJUANDA
D J A K A R T A

Client : BBD PLAZA
SURABAYA
Contract No.

IN COMING GENERATOR.1
1250KVA.220/380V-50Hz

Drawing No.	Drawn	Checked	Approved	Size	A4
Type :	Date 7-4-91	PANIEJA		Scale	
	Name HARRY STY			Page No	1

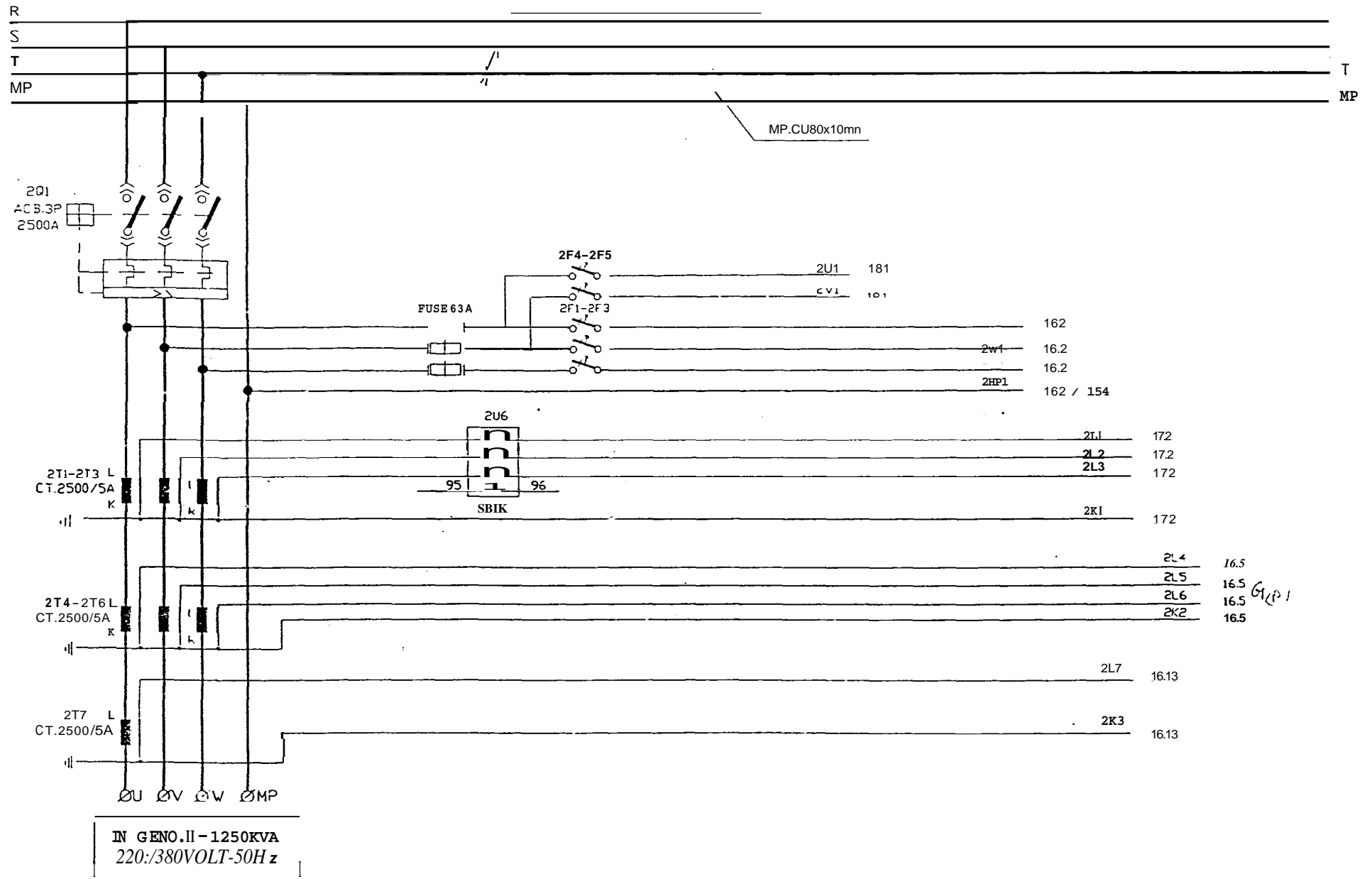

0	1	2	3	4	5	6	7	8	9	10	11	12	13	14	15	16	17	18	19
PT. PIONEER		JALAN Ir DJUANDA D J A K A R T A		Client : BBD PLAZA SURABAYA		IN COMING GENERATOR II 1250KVA.220/380V-50Hz				Drawing Nr.		Drawn		Checked		Approved		Size A4	
				Contract No.						Type :		Date 7-4-91		PANIE.JH		Scale			
												Name HARRY.Sbyl				Page Nr 15			

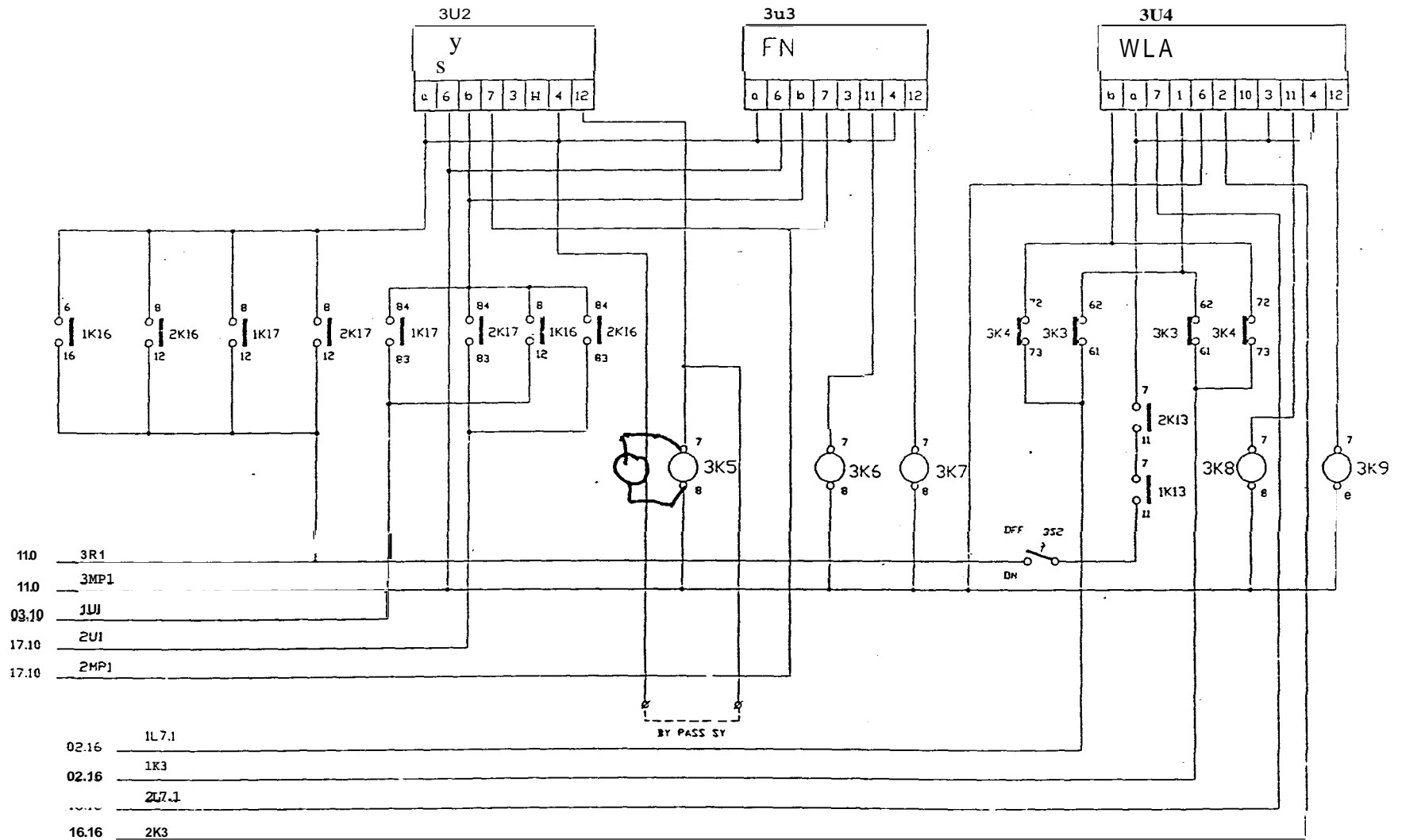

3K6		3K7		3K3		3K5	
NO	NC	NO	NC	NO	NC	NO	NC
68		69		6.11		4.11	
208		209		20.11		20.10	

0 | 1 | 2 | 3 | 4 | 5 | 6 | 7 | 8 | 9 | 10 | 11 | 12 | 13 | 14 | 15 | 16 | 17 | 18 | 19

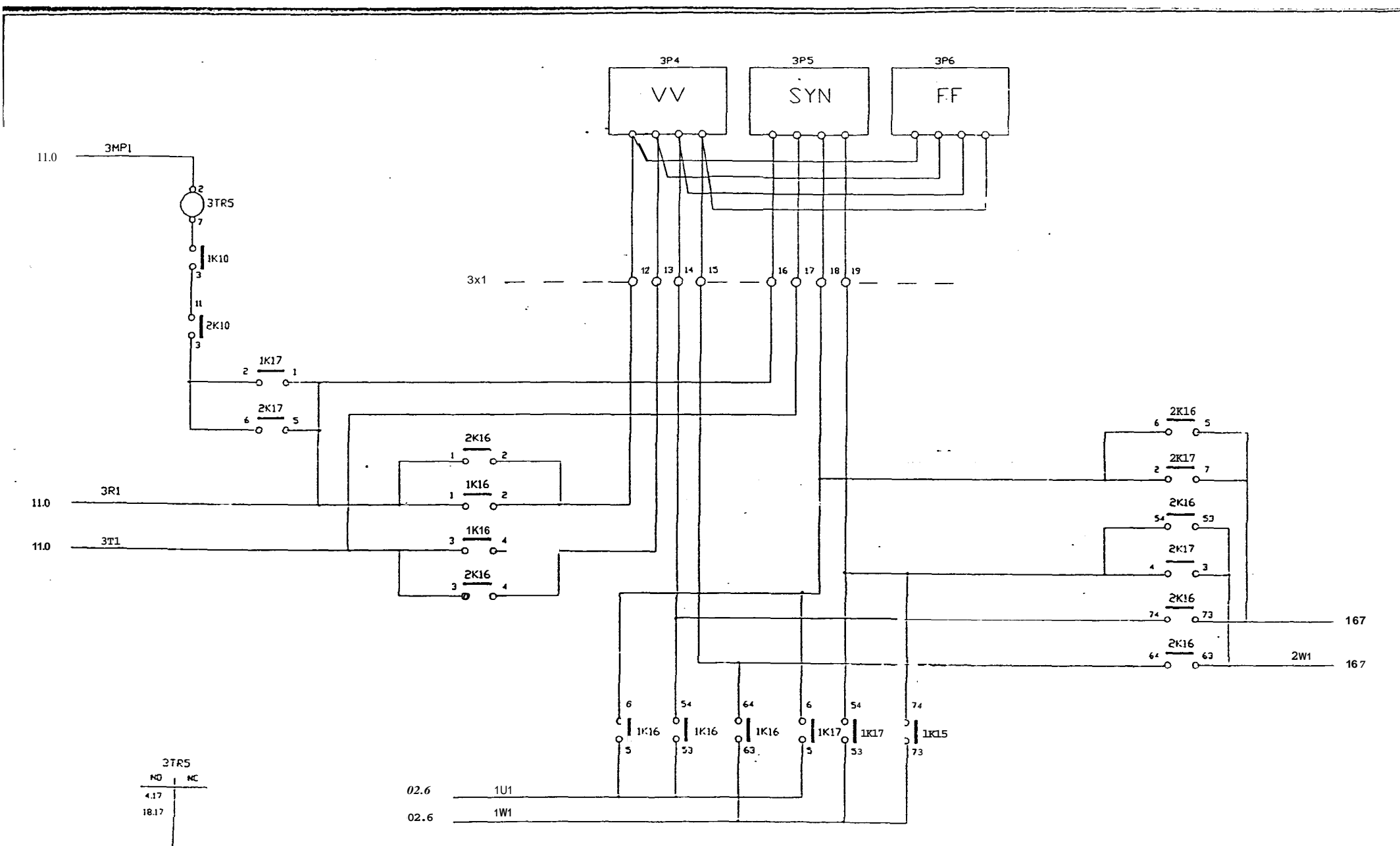

3TR5	
NO	MC
4.17	
18.17	

0	1	2	3	4	5	6	7	8	9	10	11	12	13	14	15	16	17	18	19		
P.T. PIONEER		JALAN Ir DJUANDA D J A K A R T A		Client BBD PLAZA SURABAYA		CONTROL SYNCRHONIZING GENERATOR 2x1250kva 220/350Volt-50Hz						Drawing Nr.		Drawn		Checked		Approved		Size A4	
				Contract Nr.								Type		Date 7-4-91		PANIE JH		OSCAR N		Scale	
														Name HARRY Suw						Page No.	

DAILY RECORD OPERATION GENSET .. YANMAR .. PT II

PT. PAKUWONJATI
Maintenance Electric Dept.
BBD Tower - Plaza Tunjungan II
Surabaya

Date : 11/1/02
Diesel No. : 1
Checked by :

	Inspection	Unit	Time	18 ⁰⁰	19 ⁰⁰	19 ³⁰	20 ⁰⁰	20 ³⁰	21 ⁰⁰	21 ³⁰				
			no											
P A N E L G E N E R A T O R	Current	R (KA)	600	600	600	600	600	600	600	600	400			
		S (KA)	600	600	600	600	600	600	600	600	400			
		T (KA)	600	600	600	600	600	600	600	600	400			
	Rated Out put (KW)			350	350	350	350	350	350	300	300			
	Power Factor (Cos (-))			0,8	0,8						0,8			
	Voltage	R - S (V)		395			395				395			
		R - T (V)		395			395				395			
		S - T (V)		395			395				395			
	Speed (RPM)			1500			1500				1500			
	DC (V)			26	26			26			26			
	Charging (V)			1	1	1	1	1	1	1	1			
	Hour Meter (H)													
Frequency (HZ)			50	50						50				
KWH Meter (KWH)														
P A N E L D I E S E L	Lub Oil tempt (°C)		60	60			60			60				
	Water tempt (°C)		45	45	50						50			
	Speed (RPM)													
	Hour Meter (H)													
	Charging (V)													
	KWH Meter (KWH)													
	Pressure	Side A (Kg/Cm2)	2,5	2,5							2,5			
Fuel Oil	Side B (Kg/CM2)	6	6							6				
Pressure Lub Oil (Kg/Cm2)														
E N G I N E	Genset room tempt (°C)		34	35	35	35	35				35			
	Intake	L(°C)	36								36			
		R(°C)												
	Water Coller	In(°C)	54								54			
		Out(°C)	57								57			
	Inter Coller	In(°C)	30	30	32						32			
		Out(°C)	34	34	36						36			
	Oil Coller	In(°C)	76	78	78						78			
		Out(°C)	76	74	74						74			
	Exhaust	L(°C)	550								550			
R(°C)		570	570							570				
P A N E L C O L L I N O	Raw Water I(A)													
	Pump Current II(A)		22								22			
	Colling to wer I(A)													
	Pump Current II(A)		0,5								0,5			
	Exhaust Fan Current (A)		21								21			
T O W E R	Intake Fan Current (A)													
	Compressor Pump Current (A)													
	Fuel Pump Current (A)													
Raw Water Press (Kg/Cm2)			4,8	4,0						4,8				
O T H E R S	Flow Meter		FINISH :											
	Fuel (L)		START :											
			TOTAL :											

